

Implementation Modified PQ in Single-Phase Harmonic Reduction Using Hybrid Shunt Active Power Filter with Hysteresis Control

Asep Andang, Nurul Hiron and Eka Priatna

Departement of Electrical

Siliwangi University

Tasikmalaya, Indonesia

andang@unsil.ac.id, hiron@unsil.ac.id, ekapriatna87@yahoo.co.id

Abstract— The development of the use of nonlinear loads in electric power systems today is due to the extensive use of electronics in equipment in everyday life, resulting in more significant harmonic waves being produced so that it affects the quality of the power system. The harmonic reduction has been made since harmonics are existing in the network starting by using a passive filter then active, and the last is a hybrid filter. In this study will be discussed the use of passive filters connected to the network and shunt connected with active filters as known Hybrid Active Power Filter (HAPF). The active power filter control is carried out using the hysteresis control to switch the inverter while the use of the modified PQ model is implemented to produce a reference current based on a decomposition of a single-phase load current. From the results of the simulation model, there is a decrease in harmonics to 1.45% for inductive nonlinear loads and 1.46% for complex nonlinear loads

Keywords—Harmonics, Hybrid Active Filter, Hysteresis.

I. INTRODUCTION

The use of electric power as energy that supports human life is being needed. All sectors need electricity to carry out their activities. The development of electronic technology has a significant effect on load variations, with the discovery of power electronic control, various kinds of power controls used in everyday life are easily found.

Another result of this electronic development has resulted in the development of a type of load from passive loads which has a linear response to a nonlinear load which results in a generating frequency namely harmonics which in turn affects the quality of electric power [1].

Harmonic currents formed due to nonlinear loads result in a number of problems both decreasing function in power system equipment, bursting capacitor banks and overheating transformers, vibrations and noise in electrical machines, disturbances and interferences in communication and electronic equipment, excessive neutral current increases, decreased accuracy of power meter [2]–[4].

The harmonics currents that appeared in the power system could be reduced by adding a passive filter circuit to the network. This passive filter can be set for single tuned which is used to reduce single order of harmonics, double-tuned is used to reduce two harmonic order, or bandpass filter is used to reduce based on the frequency needs of which frequency to reject[4].

When the development of nonlinear loads is not too significant, harmonics waves reduction is carried out by a passive filter and the results obtained are satisfactory. However, the development of significant nonlinear loads cannot be balanced by passive filters that are rigid, static and have weaknesses in terms of additional harmonic

resonance[5]. To improve this, gugyi [6] introduced an active filter in the form of a current and controlled voltage converter capable of dynamically eliminating currents. After that, there is another development in the form of a hybrid filter that combines the advantages of passive filters and active filters [7].

The hybrid filter has a variety of combinations, both combining two passive filters and combining passive hybrid filters with active filters with various topologies[3].

The development of the power filter has made rapid progress, especially in three-phase power filters, three-phase power filters are used in addition to being a power filter on the network also used on the Connected Grid Inverter (CGI) and in the smart grid.

The extraction of harmonic currents from load currents containing harmonics matures in three-phase hybrid active power filters because the use of three-phase power filters is more widely used both in the distribution grid and in industrial use.

single-phase active power filters is now starting to develop along with the growth of single-phase loads that contain many power electronic switching systems such as room conditioners, lamps, cooking equipment, refrigerators, personal computers[8].

The harmonic current extraction process has progressed from simple extraction[9]–[11] to the use of PQ or Instantaneous Reactive Power Theory (IRPT)[12]–[15] and Synchronous Reference frame (SRF) or known as DQ model[16]–[18]. There is also a combination of the two extraction methods carried out in research by Kumar, the harmonics current extraction using the SRF method with Inverse park to produce a quadrature part of current[19] [18].

The implementation of harmonics current extraction using SRF and PQ methods on three-phase hybrid filters cannot be implemented directly on a single-phase filter due to parameter limitations; therefore it is necessary to arrange to use SRF and PQ methods[20]

Correa[21] and Khadkikar[22] used the modified pq harmonics extraction previously by changing the three-phase pq method to single-phase pq while with the addition of time delay to make input into two phases and PLL addition. This study will discuss different modifications with previous studies. The paper will discuss shunt hybrid active power filter using single-phase harmonics current extraction with a modified PQ method. The modification is done by adding a delay that will produce a second phase with different angles then the process is carried out by transforming $\alpha\beta$ frame into dq frame, with help by v_d from dq transform, current transform

into pq frame. Simulations are performed with SIMULINK Matlab to verify the proposed model with nonlinear load. which varies, so that the performance of the model in reducing harmonics can be analyzed

II. SHUNT HYBRID ACTIVE POWER FILTER

A. Proposed Single-Phase Hybrid Power Filter Series

Fig. 1 described the proposed Single-phase hybrid filter circuit.

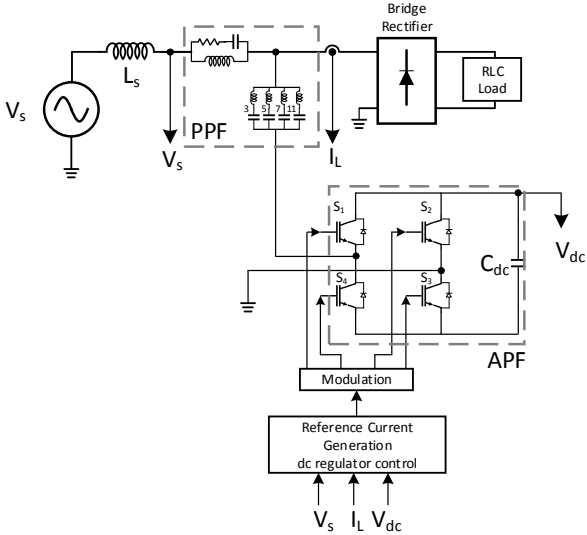

Fig 1. Proposed single-phase Hybrid active Filter Range

In the circuit, there is a passive hybrid filter that is installed in series with the grid and which is attached to the shunt with the grid. Series filters are intended for source voltage, and shunts are tuned to filter harmonics with each in the 3rd, 5th, 7th, and 11th order.

Series passive filters are chosen because excellent filter performance, does not produce harmonics from other sources and can improve power factor [23]. If compared to the passive installed parallel filter, the passive filtering filter performance installed in the series is more optimal, but because it has a large impedance, the filter installation will be quite burdensome to the source [24]. Passive shunt filter is chosen to reduce harmonics that have not been eliminated by the series passive filter. The passive shunt filter is chosen because it has minimal impedance, so it does not add a burden to the source [25].

For active power filter, circuits used Voltage Source Inverter by controlling each switch S_1 , S_2 , S_3 , and S_4 by using a dc link and separate control for the voltage regulator using a PI.

B. Modified PQ

To explain how the modified PQ works, we could see Fig. 2. The generation of reference currents using the modified PQ model is carried out for the first time for multiphase systems. The use of PQ modification on a single-phase is done by transforming the voltage. So that the single-phase source voltage is represented in the α - β coordinates by leading $\pi/2$ from the source voltage v_s [22]. Following (1), two voltages are obtained, namely $v_{s\alpha}$ and $v_{s\beta}$, which are lagging at an angle of 180° .

$$\begin{bmatrix} v_{s\alpha}(\omega t) \\ v_{s\beta}(\omega t) \end{bmatrix} = \begin{bmatrix} v_s(\omega t) \\ v_s(\omega t + (\pi/2)) \end{bmatrix} = \begin{bmatrix} V_m \sin(\omega t) \\ V_m \cos(\omega t) \end{bmatrix} \quad (1)$$

Similarly, with load current i_L when represented in α - β

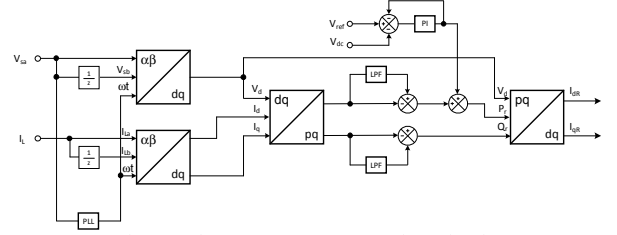

Fig 2. Reference Current Generation Circuit

coordinates, $i_{L\beta}$ will precede $i_{L\alpha}$ at $\pi/2$ according to (2)

$$\begin{bmatrix} i_{L\alpha}(\omega t) \\ i_{L\beta}(\omega t) \end{bmatrix} = \begin{bmatrix} i_L(\omega t + \phi_L) \\ i_L(\omega t + \phi_L + \pi/2) \end{bmatrix} \quad (2)$$

The magnitude of the load current in the α - β coordinate is transformed to a dq quantity by equation (3) [19] to produce a load current on the d axis i_{Ld} and current on the q axis i_{Lq} .

$$\begin{bmatrix} i_{Ld} \\ i_{Lq} \end{bmatrix} = \begin{bmatrix} \sin \omega t & -\cos \omega t \\ \cos \omega t & \sin \omega t \end{bmatrix} \begin{bmatrix} i_{L\alpha} \\ i_{L\beta} \end{bmatrix} \quad (3)$$

Likewise, with the voltage so that it can be v_d and v_q but in this paper, the just v_d use in the next process. Transformed current and voltage in coordinates DQ to PQ is made using the (4) and produces p in the form of active power in the grid and q reactive power in the grid

$$\begin{bmatrix} p \\ q \end{bmatrix} = \frac{v_d}{2} \begin{bmatrix} i_d \\ -id_q \end{bmatrix} \quad (4)$$

Where p and q are the sums of the dc components that are responsible for the values of active and reactive fundamental power and ac which are responsible for harmonic power. Alternatively, in the form of equations as below [26].

$$p = \bar{p} + \tilde{p} \quad (5)$$

$$q = \bar{q} + \tilde{q} \quad (6)$$

Real power p is a combination of the average part \bar{p} also, the oscillating part \tilde{p} likewise for imaginary power q consists of \bar{q} is the average part and \tilde{q} is oscillating part, also symbolizes harmonics, especially in the load current Extraction p is made by using a lower pass filter to find out the harmonics currents then subtracted so that what remains is the value of the harmonic load.

After obtaining a harmonic value then it is converted into a reference current with the d-q coordinate that will be used as a reference in inverter modulation.

PI control is used in the regulation of dc voltage to control the dc voltage in VSI to be stable according to the reference.

C. Modulation

After obtaining the reference, current flow from the PQ model contraction modified, then using hysteresis control is to compare the results of reference current generation with the conditions of switching on each leg so that the control for two inverter legs is produced. Fig. 3 shown block of PWM modulation control with Hysteresis. While the truth table for switches S_1 , S_2 , S_3 and S_4 can be seen in Table I

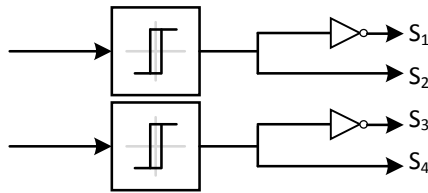

Fig. 3. Circuit of SHAPF modulation inverter

TABLE I
TRUTH TABLE FOR S1, S2, S3, AND S4

Kondisi	S1	S2	S3	S4
$I_{dr} < I_L$	0	1		
$I_{dr} > I_L$	1	0		
$I_{qr} < I_L$			0	1
$I_{qr} > I_L$			1	0

III. SIMULATION AND RESULT

To find out the performance of the model that is built, simulation and verification are done by using the Matlab SIMULINK program, where the results of the system implementation in the form of Simulink as shown in Fig. 4.

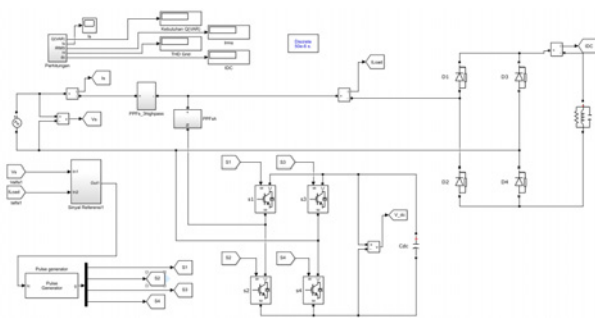

Fig. 4. Model implementation in SIMULINK

Simulation is carried out using the parameters shown in table II using de la Rosa formula [4]

TABLE II
SIMULATION PARAMETERS

Description	Symbol	Value
R series passive filter	R_f	0,06 Ω
L series passive filter	C_f	84 μF
C series passive filter	L_f	2,4 mH
L 3 rd Passive shunt Filter	L_{fa}	0.061484 H
C 3 rd Passive shunt Filter	C_{fa}	1.83×10^{-5} F
R 3 rd Passive shunt Filter	R_{fa}	0.585566 Ω
L 5 th Passive shunt Filter	L_{fb}	0.020495 H
C 5 th Passive shunt Filter	C_{fb}	1.98×10^{-5} F
R 5 th Passive shunt Filter	R_{fb}	0.325314 Ω
L 7 th Passive shunt Filter	L_{fc}	0.010247 H
C 7 th Passive shunt Filter	C_{fc}	2.02×10^{-5} F
R 7 th Passive shunt Filter	R_{fc}	0.22772 Ω
L 11 th Passive shunt Filter	L_{fd}	0.004099 H
C 11 th Passive shunt Filter	C_{fd}	2.04×10^{-5} F
R 11 th Passive shunt Filter	R_{fd}	0.143138 Ω
Dc link Capacitor	C_{dc}	177,6 μF
Source Inductance	L_s	1 μH
Source Resistance	R_s	0,01 Ω

A. Simulation using inductive Nonlinear Loads

The non-linear load used is uncontrolled full-bridge rectifier with RL load. The load configuration, as shown in Fig. 5 is a series relationship between R and L.

For the value of loading in the first simulation test as in table III

TABLE III
INDUCTIVE LOAD PARAMETERS

Component	Symbol	Value
Resistor	R	50 Ohm
Inductor	L	79,6 mH

The Simulation results obtained current and voltage

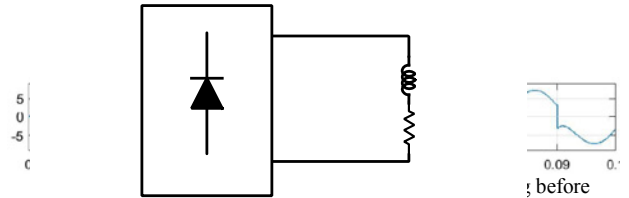

Fig. 5. R and L load configurations

waveforms when before installing a Shunt hybrid active power filter.

From Fig. 6, it can be seen that the waveform load current is hugely distorted by harmonics and has a direct effect on the source current resulting in distorted source currents by harmonics.

Fig.7 shown the spectrum of polluted current by harmonics current. The number of harmonics that pollute the source current can be seen from the amount of THD following the lower current spectrum, which is equal to 23.7%, where the dominant harmonics in this series are the 3rd, 5th, 7th, 11th, and 13th order harmonics.

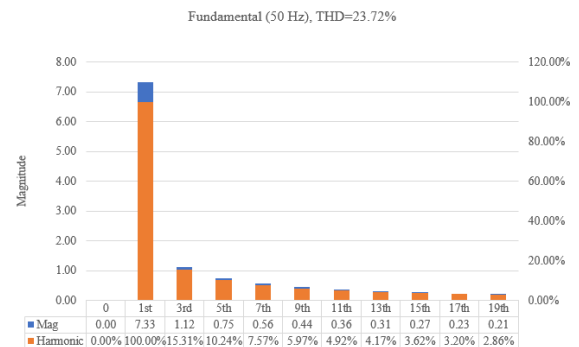

Fig. 7. Harmonic spectrum on inductive load testing before SHAPF installation

A single-phase active filter is installed to reduce harmonics current where the parameters are used according to table I. The passive filter circuit is used to reduce third-order harmonics while the rest is carried out by the shunt filter.

After the installation of a hybrid filter, a simulation was carried out to determine the effectiveness of using this single-

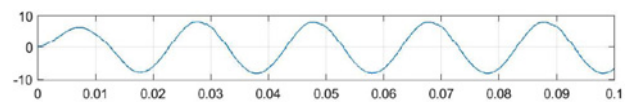

Fig. 8. Source current waveform on inductive load testing after filter installation

phase hybrid power filter and from the test results in the waveform, as shown in Fig. 8.

For the waveform of the source current, there is a very significant change in shape to sinusoidal. There is a transient process in the first half-wave, this is influenced by dc voltage control by the amount of PI.

There is a decrease in harmonic current at the source so that the waveform of the source current is almost nearly pure sinusoidal. To find out how much THD is lowered, an FFT analysis is carried out to produce a spectrum like Fig. 9.

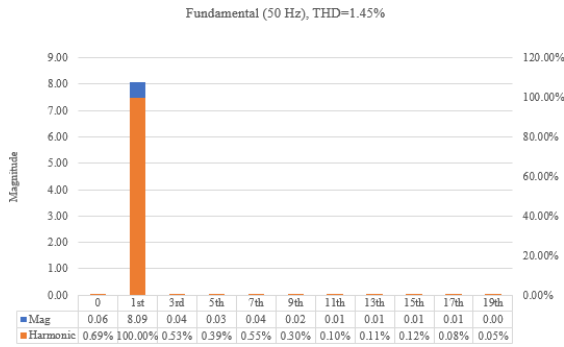

Fig. 9. Harmonic spectrum on inductive load testing after filter installation

From Fig. 9, it is known that THD reduction occurs very significantly from 23.7% to 1.45%. The most significant decrease in third-order harmonics becomes 0.48% then the 5th order becomes 0.49%, while the 7th order becomes the biggest which is 0.65%

It can also be seen that the voltage waveform is not affected by the installation of a hybrid filter.

The details of parameter changes from before and after installation can be seen in table IV

TABEL IV
RESULTS INDUCTIVE LOAD TEST

Parameters	Before	After
THD (%)	23.72	1.45
I_s (A)	7.33	8.1
I_L (A)	7.33	5.58
V_s (V)	400	400

There was a decrease in the current magnitude of the load from 7.33 to 5.58 ampere, but on the source, there was an increase of 0.77 ampere due to the addition of series filters.

B. Simulation using of Complex Nonlinear Load

Another test conducted is uncontrolled full-bridge rectifier with RLC load. The test range can be viewed, as shown in Fig. 10.

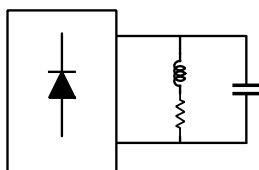

Fig. 10. RLC Load Configuration

This test was conducted to view the filter response to nonlinear loads with a shunt load of RLC. Table 4 shown the RLC value.

TABEL 4
COMPLEX LOAD VALUE

Component	Symbol	Value
Resistor	R	50 Ohm
Inductor	L	79,6 mH
Capacitor	C	1 μ F

Simulated results without the use of hybrid power filters acquired a highly distorted load current distortion, and this affects the source current so that the source current is distorted too. This waveform can be seen in Fig. 11.

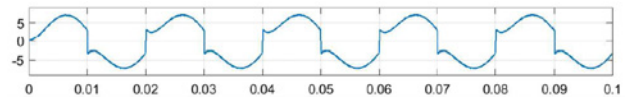

Fig. 11. Source current waveform before in install filter on complex load simulation

FFT analysis results in Fig. 12, showing the magnitude of THD distortion that pollutes the system is at 23.92%. It is dominated by odd-order distortion, where the largest in the 3rd order distortion.

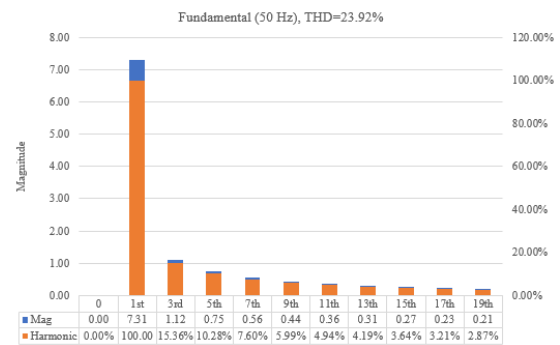

Fig. 12. Harmonic spectrum on complex load testing before filter installation

The hybrid power filter installation with the value parameter is the same as the previous test to test the extent of this hybrid power filter's flexibility in reducing distortion with the changing load. The performance of this filter will be seen in the reduction of distortion with attention to a decrease of THD before and after installation.

After installing the hybrid power filter on the circuit then retested the model and got the waveform with the like in Fig. 13.

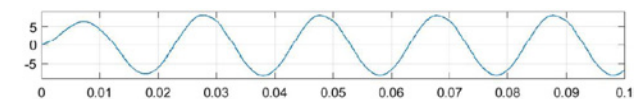

Fig. 13. Source current waveform after hybrid filter installs on complex load simulation

It looks like in the previous test that the harmonic decline was shown with the changing of the source current waveforms to approach pure sinusoidal.

Similarly, the presence of hybrid power filters is known to load current does not affect the source current so that the current distortion only contained in the load only

To know how big of THD from the harmonic distortion in the model, then it is done decomposition of the current wave by using FFT so that the wave spectrum is obtained as in Fig. 14.

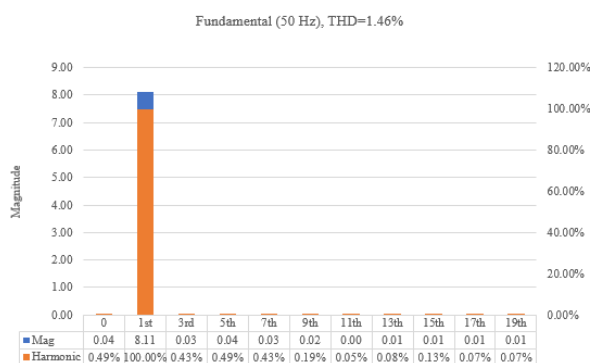

Fig. 14. Harmonic spectrum on complex load testing after filter installation

The significant decline occurred at the 3rd, 5th and 7th Order distortion, resulting in a total THD of the circuit being 1.46%.

The parameter changes before testing and after testing can be seen in table V.

TABEL V
TEST RESULT

Parameter	Before	After
THD (%)	23.92	1.46
I_s (A)	7.31	8.121
I_l (A)	7.31	5.546
V_s (V)	400	400

As with previous tests, there was a drop in the current to the load, but there was an increase in currents from the current source as well as previous tests due to series filters that weighed on the system.

IV. CONCLUSION

From the test results were shown that hybrid filter active the serial topology of filter and active shunt-passive filter with hysteresis method and the generation of reference currents with modified PQ model able to reduce distortion that occurs both due to Nonlinear load with RL load with a decrease of 21.27% and for RLC load decreased THD by 22.42%. However, from all tests, there is a rise of source currents due to series filter installation. In general, the use of hysteresis control and reference current generation method with modified PQ model can work at varying nonlinear load conditions.

V. REFERENCES

[1] E. H. Watanabe, H. Akagi, and M. Aredes, "Instantaneous p-q power Theory for compensating nonsinusoidal systems," in *2008 International School on Nonsinusoidal Currents and Compensation*, 2008, vol. 84, no. 6, pp. 1–10.

[2] C. Lam, M. Wong, W. Choi, X.-X. Cui, H.-M. Mei,

and J.-Z. Liu, "Design and Performance of an Adaptive Low-DC-Voltage-Controlled LC-Hybrid Active Power Filter With a Neutral Inductor in Three-Phase Four-Wire Power Systems," *IEEE Trans. Ind. Electron.*, vol. 61, no. 6, pp. 2635–2647, Jun. 2014.

[3] B. Singh, A. Chandra, and Kamal Al-Haddad, *POWER QUALITY PROBLEMS AND MITIGATION TECHNIQUES*, 1st ed., vol. 37, no. 4. sussex: John Wiley and Sons Ltd, 2015.

[4] F. C. D. La Rosa, *Harmonics, Power System, and Smart Grids*, 2nd ed. Boca Raton: CRC Press, 2015.

[5] S. Mikkili and A. K. Panda, *Power Quality Issues Current Harmonics*. Boca Raton: CRC Press, 2016.

[6] L. Gyugyi and E. . Strycula, "Active AC Power Filters," in *IEEE IAS Annual Meeting*, 1976, pp. 529–535.

[7] S. P. Litrán, P. Salmerón, and R. S. Herrera, "Hybrid Active Power Filter: Design Criteria," in *International Conference on Renewable Energies and Power Quality*, 2011, vol. 1, no. 9, pp. 69–74.

[8] C.-S. Lam and M.-C. Wong, *Design and Control of Hybrid Active Power Filters*. Berlin, Heidelberg: Springer Berlin Heidelberg, 2014.

[9] N. F. A. Rahman, M. K. Hamzah, S. Z. M. Noor, and A. S. A. Hasin, "Single-Phase Hybrid Active Power Filter Using Single Switch Parallel Active Filter and Simple Passive Filter," in *2009 International Conference on Power Electronics and Drive Systems (PEDS)*, 2009, pp. 40–45.

[10] S. K. Dash and G. Panda, "Development of 1-ph Hybrid Active Power Filter with an Efficient FPGA Platform for Power Conditioning," in *2013 IEEE 1st International Conference on Condition Assessment Techniques in Electrical Systems (CATCON)*, 2013, pp. 186–190.

[11] A. Javadi and K. Al-haddad, "A single-phase transformerless active filter with reduced DC-link voltage," *2014 IEEE 23rd Int. Symp. Ind. Electron.*, pp. 2143–2148, 2014.

[12] M. A. Mulla, P. Patel, R. Chudamani, and A. Chowdhury, "A simplified control strategy for Series Hybrid Active Power Filter that compensat voltage sag, swell, unbalance and harmonics," in *2012 IEEE 5th India International Conference on Power Electronics (IICPE)*, 2012, pp. 1–6.

[13] A. Chowdhury, C. Rajagopalan, and M. A. Mulla, "Hardware implementation of series hybrid active power filter using a novel control strategy based on generalised instantaneous power theory," *IET Power Electron.*, vol. 6, no. 3, pp. 592–600, Mar. 2013.

[14] Y. Hoon, M. Mohd Radzi, M. Hassan, and N. Mailah, "A Refined Self-Tuning Filter-Based Instantaneous Power Theory Algorithm for Indirect Current Controlled Three-Level Inverter-Based Shunt Active

- Power Filters under Non-sinusoidal Source Voltage Conditions,” *Energies*, vol. 10, no. 3, p. 277, Feb. 2017.
- [15] C.-S. Lam, L. Wang, S.-I. Ho, and M.-C. Wong, “Adaptive Thyristor-Controlled LC-Hybrid Active Power Filter for Reactive Power and Current Harmonics Compensation With Switching Loss Reduction,” *IEEE Trans. Power Electron.*, vol. 32, no. 10, pp. 7577–7590, Oct. 2017.
- [16] Gururaj M V, Vinatha U., and Jayasankar V N, “Interconnection of wind-solar hybrid Renewable Energy source to the 3 phase-3 wire distribution system along with power quality improvements at the grid side,” in *2015 International Conference on Power and Advanced Control Engineering (ICPACE)*, 2015, pp. 168–172.
- [17] Jayasankar V N, Gururaj M V, and Vinatha U., “A study on hybrid Renewable Energy Source interface to the non-ideal grid at distribution level with power quality improvements,” in *2016 IEEE 6th International Conference on Power Systems (ICPS)*, 2016, no. 1, pp. 1–5.
- [18] C. Nagaraj and S. Mangaluru, “Improvement of Harmonic Current Compensation Energy System,” in *2016 IEEE 6th International Conference on Power Systems (ICPS)*, 2016.
- [19] P. S. Magdum and U. T. Patil, “Development of Single Phase Shunt Active Power Filter .,” in *International Conference on Inventive Communication and Computational Technologies (ICICCT 2017)*, 2017, no. Icicct, pp. 351–355.
- [20] B. J. Kumar and A. Chandramouli, “Modeling and simulation of nine-level cascaded H-bridge inverter based shunt active power filter for single-phase distribution system,” in *2017 International Conference on Inventive Computing and Informatics (ICICI)*, 2017, no. Icici, pp. 675–680.
- [21] J. M. Corrêa and F. A. Farret, “Application of a Modified Single-Phase P-Q Theory in the Control of Shunt and Series Active Filters in a 400 Hz Microgrid,” in *2005 IEEE 36th Power Electronics Specialists Conference*, 2005, pp. 2585–2591.
- [22] V. Khadkikar, A. Chandra, and B. N. Singh, “Generalised single-phase p-q theory for active power filtering: simulation and DSP-based experimental investigation,” *IET Power Electron.*, vol. 2, no. 1, pp. 67–78, 2009.
- [23] T. Dalgleish *et al.*, *Power Electronics Handbook*, 4th ed., vol. 136, no. 1. Oxford: Butterworth-Heinemann Elsevier, 2018.
- [24] R. Jayswal, S. Marathe, M. Shastri, and K. Panchal, “Comparative Analysis of Series & Parallel Passive Filter Using PSCAD Simulation,” vol. 1, pp. 593–582, 2018.
- [25] Pranjali Bafila, “Power Quality improvement using passive shunt filter,” *Am. J. Appl. Sci.*, vol. 6, no. 3, pp. 396–400, 2010.
- [26] H. Akagi, E. H. Watanabe, and M. Aredes, *Instantaneous Power Theory and Applications to Power Conditioning*, 1st ed. New Jersey: John Wiley & Sons Ltd, 2007.